

.098" (2,5mm) Wire-to-wire Connectors

Specifications

- Current rating: 3A AC, DC max.
- Temperature Range: -25°C ~ +85°C.
(including temperature rise)
- Contact resistance: Initial value/10mΩ max.
After environmental testing/20mΩ max.
- Insulation Resistance: 500 MΩ min.
- Withstand voltage: 1,000V AC/minute
- Applicable Wires: AWG #26~#22
- Applicable panel thickness: .020"~.079" (0.5~2.0mm)

25009TM Series

Crimp Terminal

- Used in 25009HF-N series housing
- Applicable wires: AWG #26~#22
- Material: Tin-plated brass
- Insulation O.D.: .047" (1.2mm)~
.071" (1.8mm)

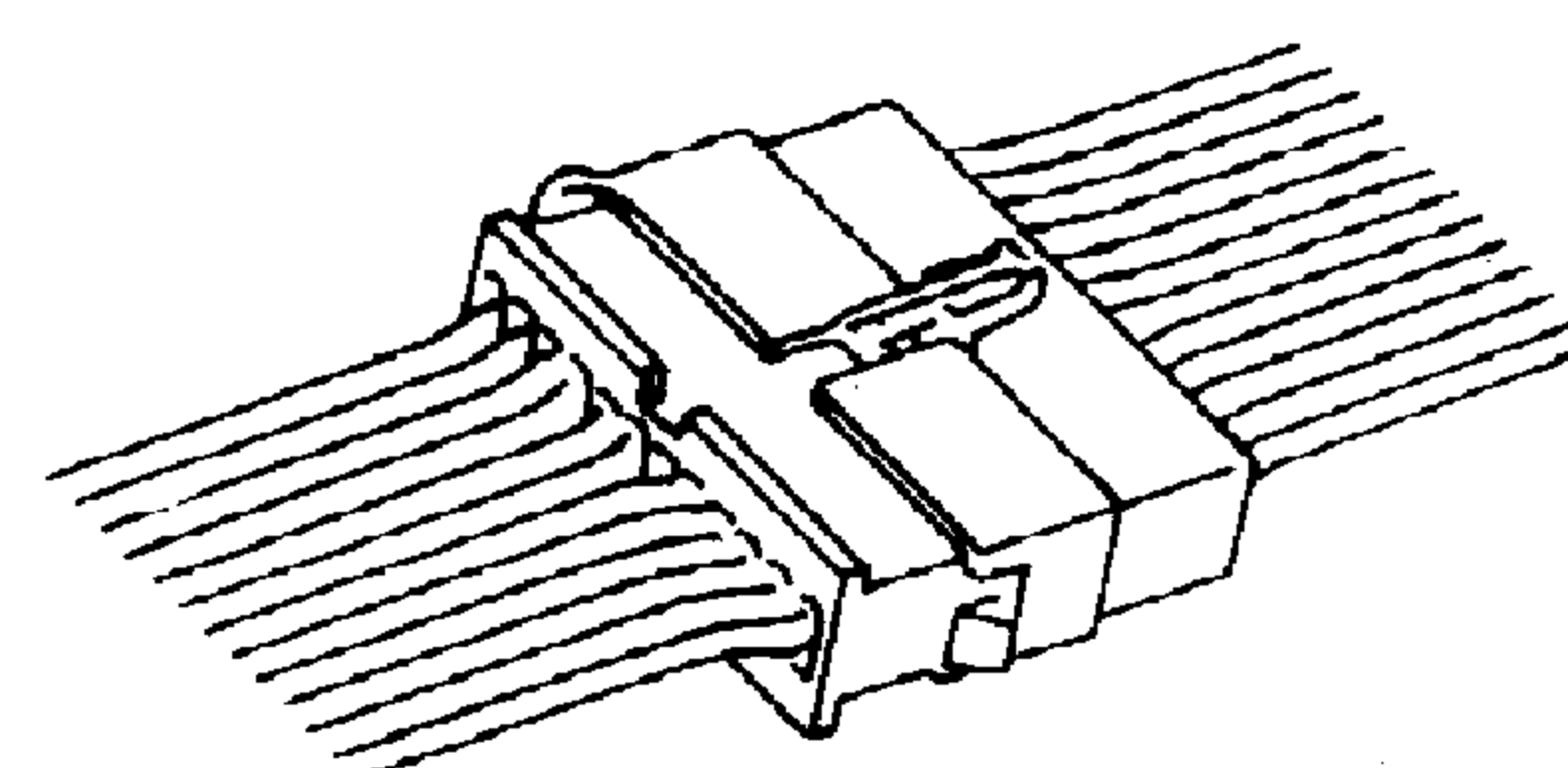
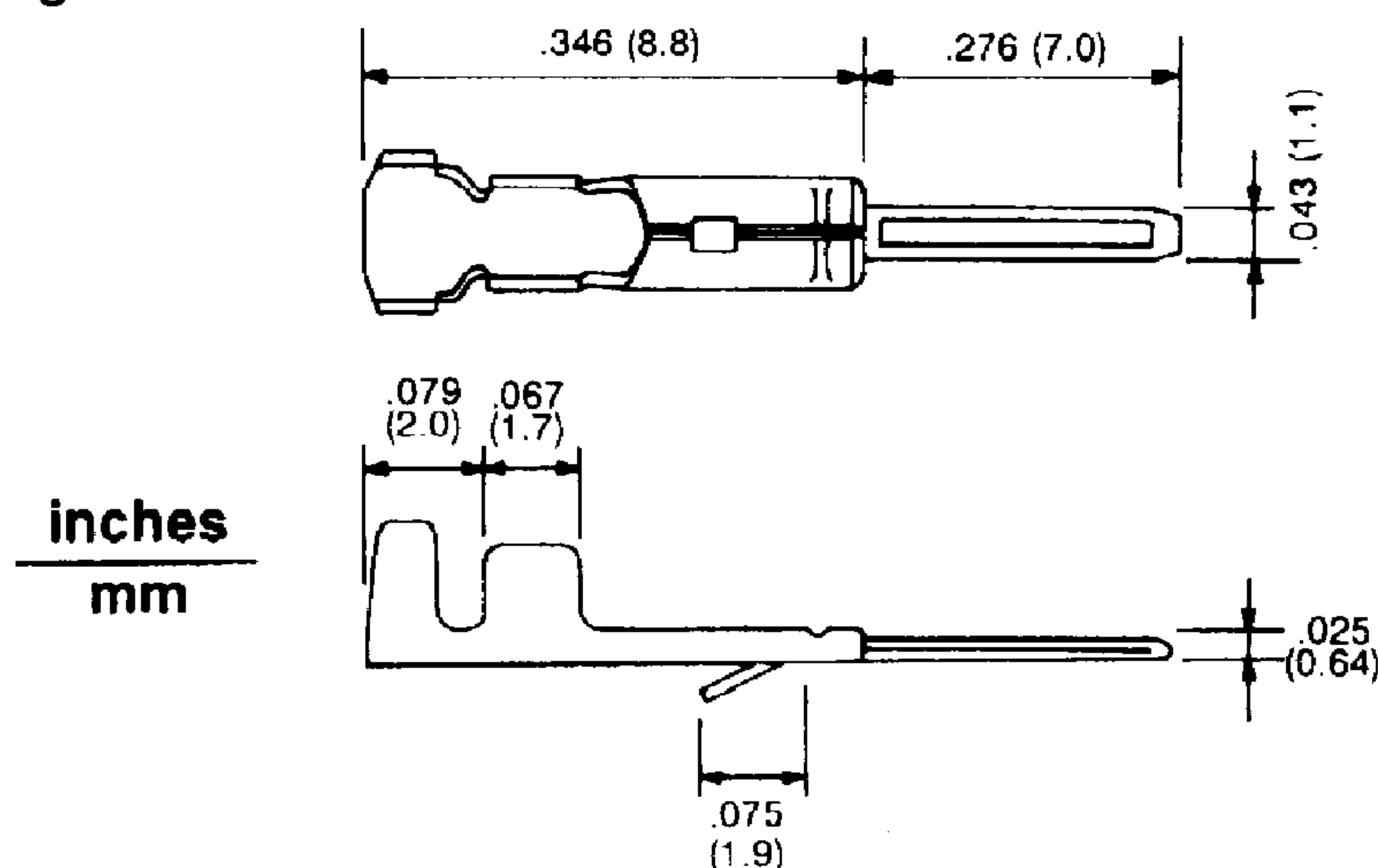

25009HF-N Series

Crimp Terminal Housing

- Material: 94V-2 nylon
- 2-12 circuits available
- Standard color: Black
- Accepts 25009TM terminal
- Mates with 25009HM-N series housing

2P-12P

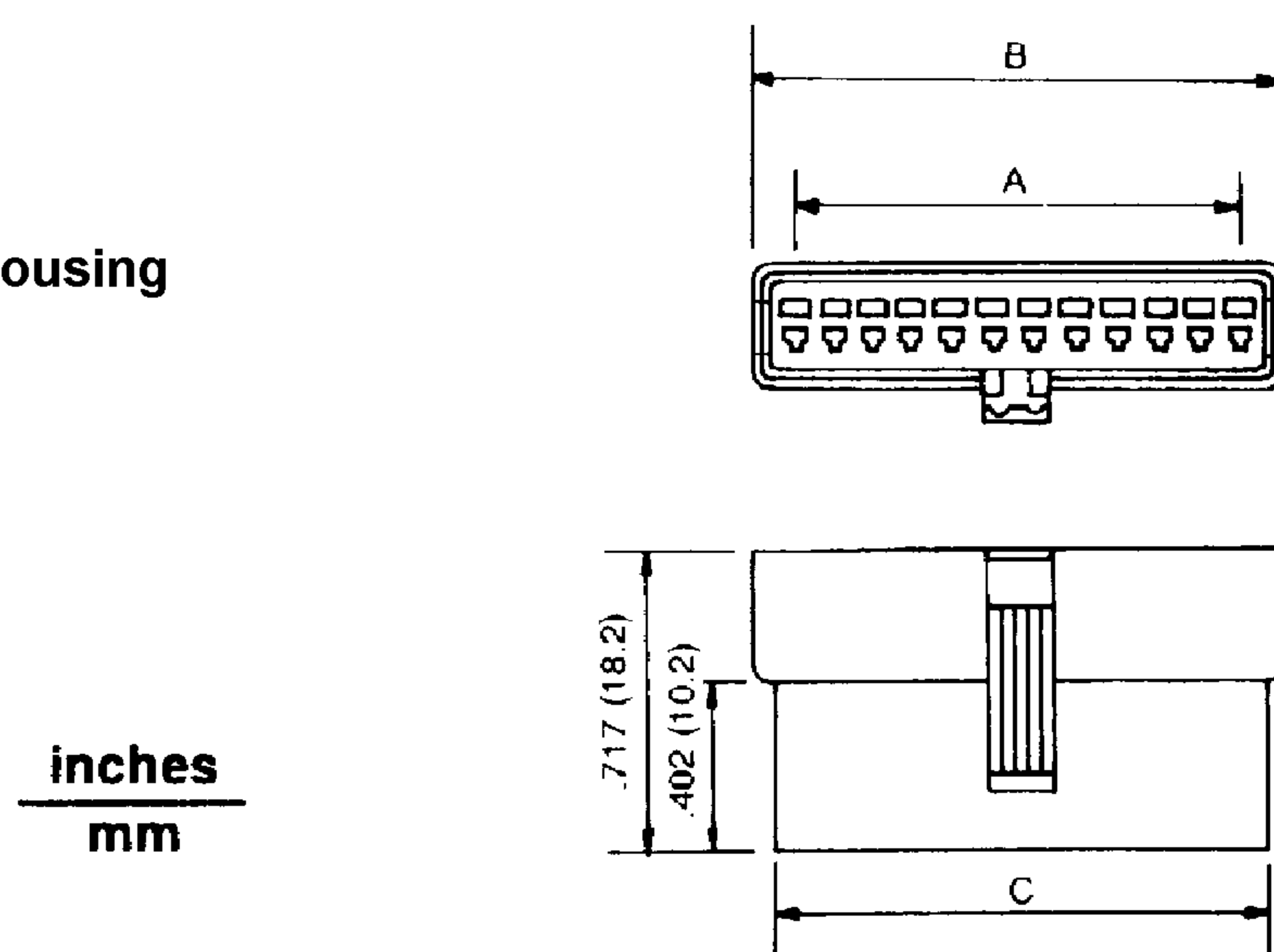

Dimensional Information - in. (mm)

Circuits	Dim. A	Dim. B	Dim. C	Circuits	Dim. A	Dim. B	Dim. C
2	.098 (2.5)	.315 (8.0)	.217 (5.5)	8	.689 (17.5)	.906 (23.0)	.807 (20.5)
3	.197 (5.0)	.413 (10.5)	.315 (8.0)	9	.787 (20.0)	1.004 (25.5)	.906 (23.0)
4	.295 (7.5)	.512 (13.0)	.413 (10.5)	10	.886 (22.5)	1.102 (28.0)	1.004 (25.5)
5	.394 (10.0)	.610 (15.5)	.512 (13.0)	11	.984 (25.0)	1.201 (30.5)	1.102 (28.0)
6	.492 (12.5)	.709 (18.0)	.610 (15.5)	12	1.083 (27.5)	1.299 (33.0)	1.201 (30.5)
7	.591 (15.0)	.807 (20.5)	.709 (18.0)				